



300 S. DAYTON ST.
 DAVISON, MI 48423
 PH: 810-503-9000
 FAX: 810-653-8714

PART NO.

FVS21

DESCRIPTION:

21 IN. Spigot-Mounted Flap Valve
 for Large Diameter PVC Sewer Pipe

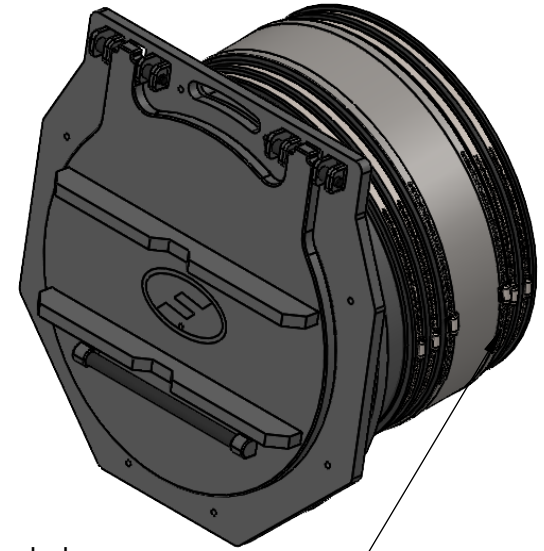
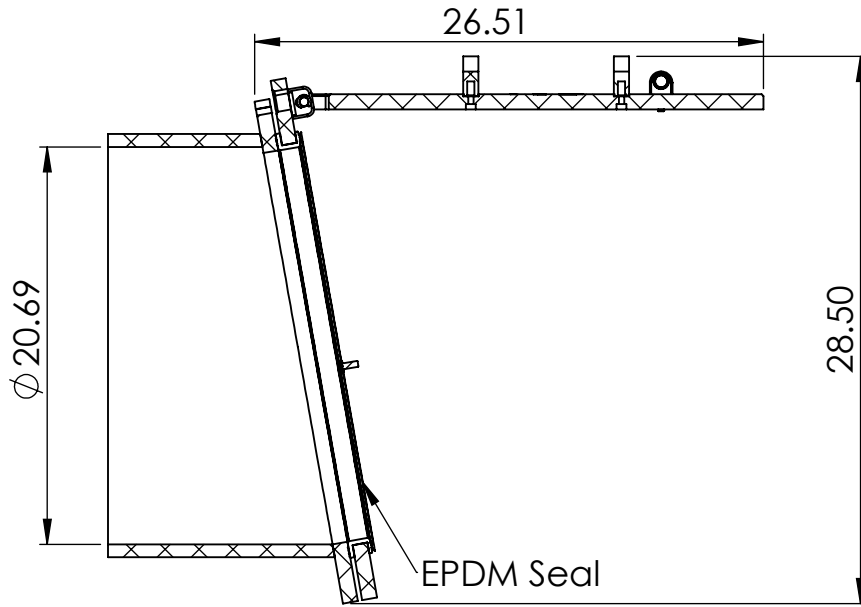

Coupling Sold Separately,
 Contact Customer Service with Pipe OD

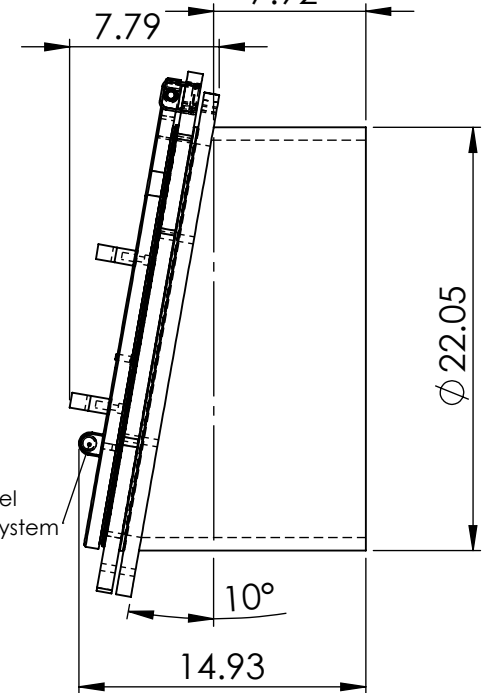
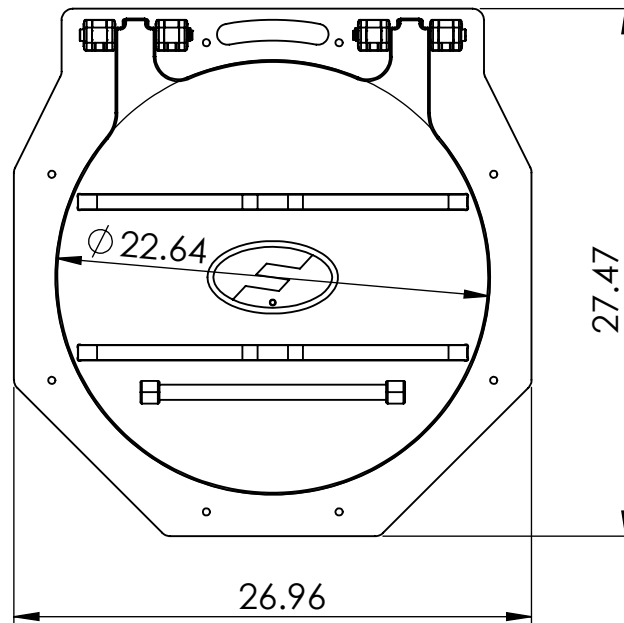

NOTE: FOR GRAVITY DRAINAGE APPLICATIONS ONLY

1. Working pressure of 10.75 PSI
2. Cracking head 0.4 PSI
3. Coupling Sold Separately
4. Exceeds the leakage rate and manufacturing requirements as per BS 7775 and DIN 19569-4 for a Class 5 valve.

PROPRIETARY AND CONFIDENTIAL
 THE INFORMATION CONTAINED IN THIS
 DRAWING IS THE SOLE PROPERTY OF
 FERNCO, INC. ANY REPRODUCTION IN
 PART OR AS A WHOLE WITHOUT THE
 WRITTEN PERMISSION OF FERNCO, INC.
 IS PROHIBITED.

TOLERANCES:
 FRACTIONAL ± 1/4"
 .XX = ± .06
 ANG. = +3°
 UNLESS OTHERWISE SPECIFIED

GASKET	EPDM RUBBER	CONFORMS TO:	PART WEIGHT:	AUTHOR:	DATE:	SCALE:
BODY	HMWPE	BS 7775	44.1 lbs.	TYLER KELLER	5/20/2026	NOT TO SCALE
STEEL COMPONENTS	316SS	DIN 19569-4	REVISION:	CHECKER:	UNITS:	SHEET: 1 OF 1
			A		INCHES	