



300 S. DAYTON ST.  
DAVISON, MI 48423  
PH: 810-503-9000  
FAX: 810-653-8714

PART NO.

FVS20-1

DESCRIPTION:

20 IN. IPS Spigot-Mounted Flap Valve

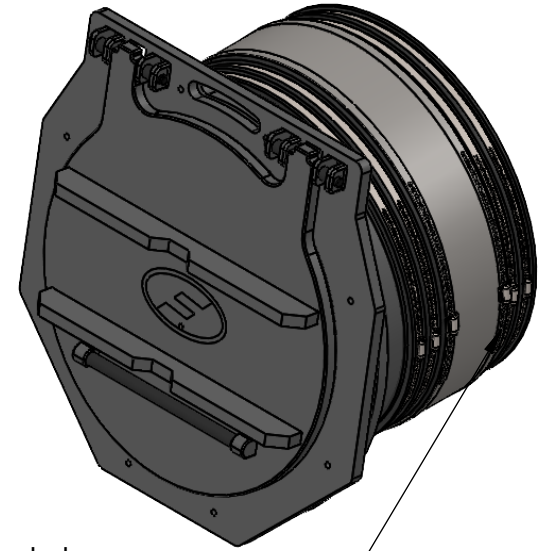
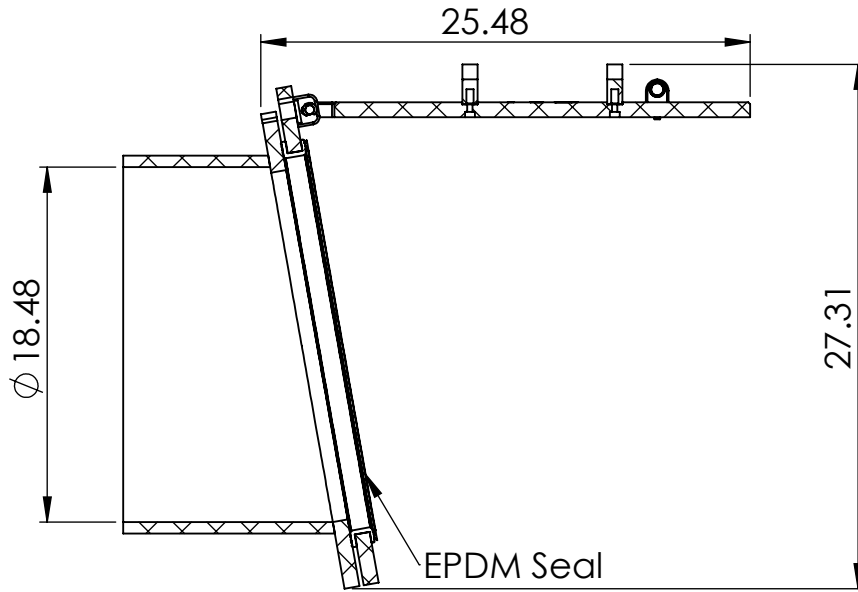

Coupling Sold Separately,  
Contact Customer Service with Pipe OD

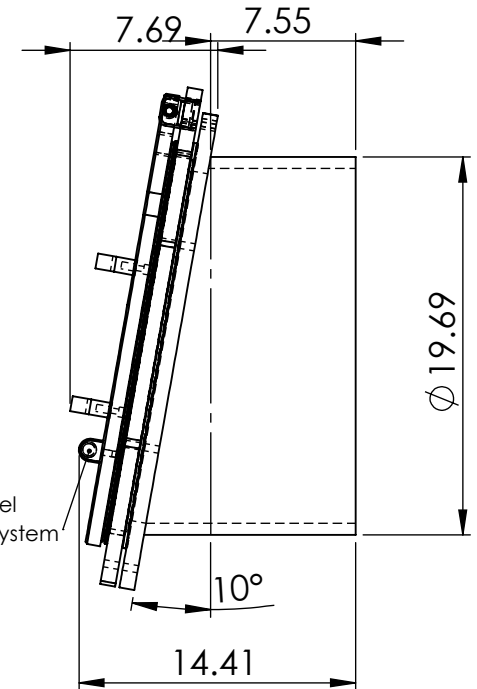
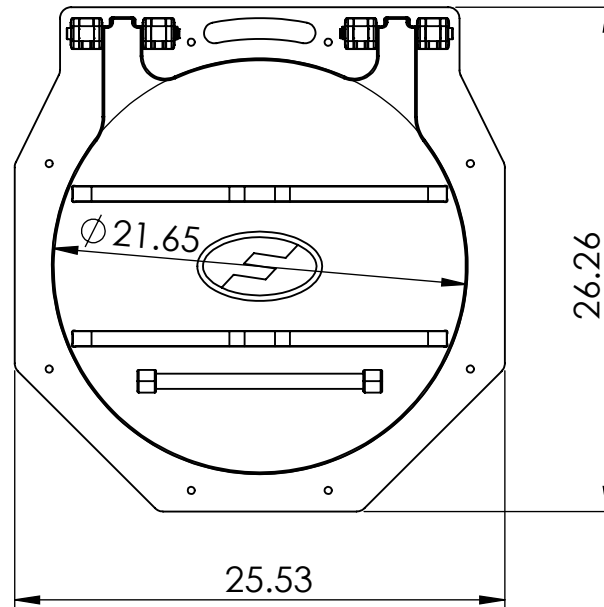

Enclosed 316 Steel  
Counterweight System

**NOTE: FOR GRAVITY DRAINAGE APPLICATIONS ONLY**

1. Working pressure of 10.75 PSI
2. Cracking head 0.4 PSI
3. Coupling Sold Separately
4. Exceeds the leakage rate and manufacturing requirements as per BS 7775 and DIN 19569-4 for a Class 5 valve.

PROPRIETARY AND CONFIDENTIAL  
THE INFORMATION CONTAINED IN THIS  
DRAWING IS THE SOLE PROPERTY OF  
FERNCO, INC. ANY REPRODUCTION IN  
PART OR AS A WHOLE WITHOUT THE  
WRITTEN PERMISSION OF FERNCO, INC.  
IS PROHIBITED.

TOLERANCES:  
FRACTIONAL ± 1/4"  
.XX = ± .06  
ANG. = +3°  
UNLESS OTHERWISE SPECIFIED

GASKET	EPDM RUBBER
BODY	HMWPE
STEEL COMPONENTS	316SS

CONFORMS TO:	BS 7775 DIN 19569-4
--------------	------------------------

PART WEIGHT:	39.7 lbs.
REVISION:	A

AUTHOR:	TYLER KELLER
CHECKER:	

DATE:	5/20/2026
UNITS:	INCHES

SCALE:	NOT TO SCALE
SHEET:	1 OF 1