



300 S. DAYTON ST.  
 DAVISON, MI 48423  
 PH: 810-503-9000  
 FAX: 810-653-8714

PART NO.

FVS16-1

DESCRIPTION:

16 IN. IPS Spigot-Mounted Flap Valve

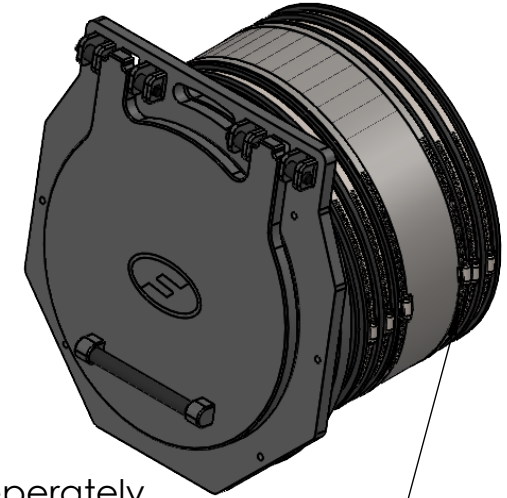
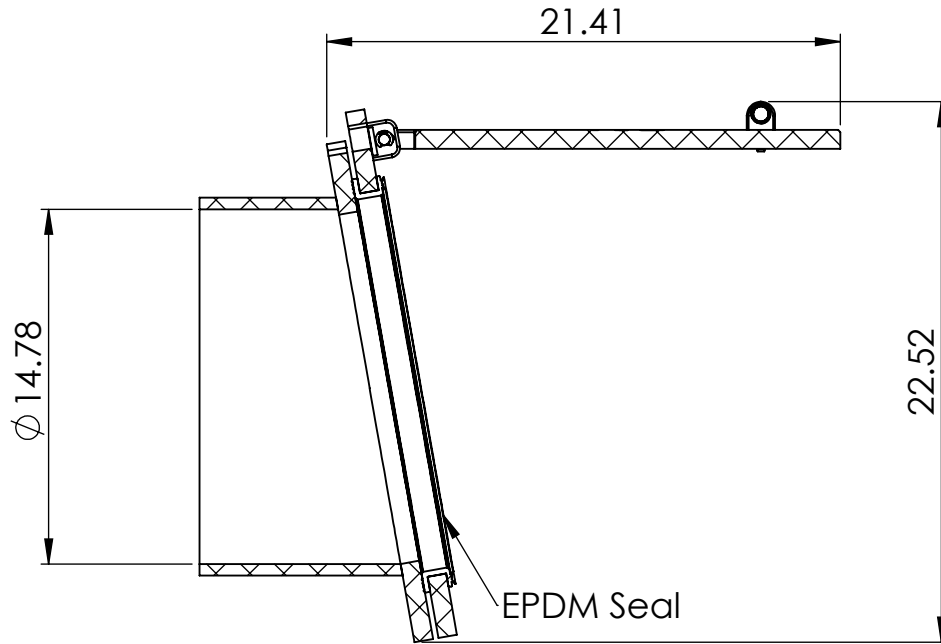

Coupling Sold Separately,  
 Contact Customer Service with Pipe OD  
 6.82

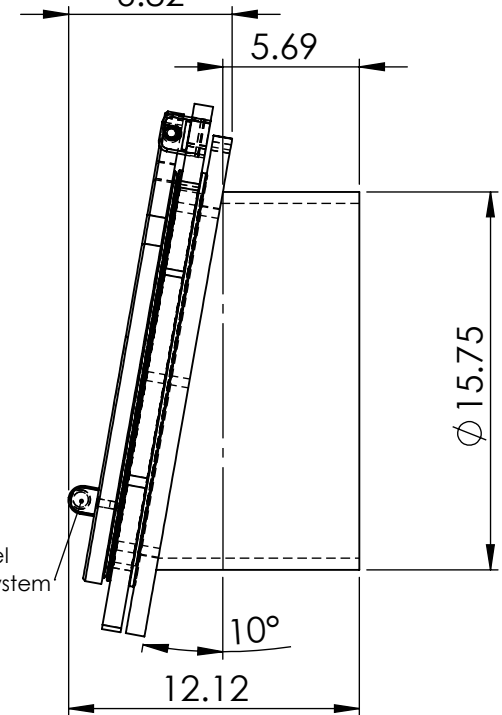
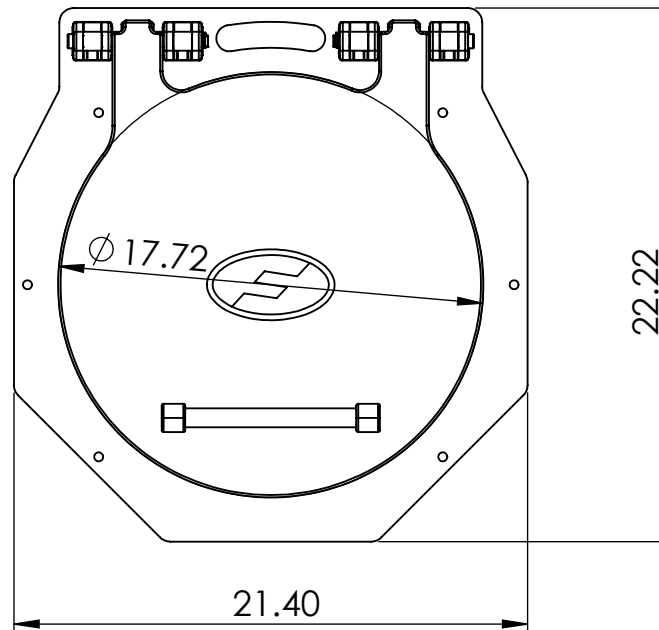

Enclosed 316 Steel  
 Counterweight System

**NOTE: FOR GRAVITY DRAINAGE APPLICATIONS ONLY**

1. Working pressure of 10.75 PSI
2. Cracking head 0.4 PSI
3. Coupling Sold Separately
4. Exceeds the leakage rate and manufacturing requirements as per BS 7775 and DIN 19569-4 for a Class 5 valve.

PROPRIETARY AND CONFIDENTIAL  
 THE INFORMATION CONTAINED IN THIS  
 DRAWING IS THE SOLE PROPERTY OF  
 FERNCO, INC. ANY REPRODUCTION IN  
 PART OR AS A WHOLE WITHOUT THE  
 WRITTEN PERMISSION OF FERNCO, INC.  
 IS PROHIBITED.

TOLERANCES:  
 FRACTIONAL ± 1/4"  
 .XX = ± .06  
 ANG. = +3°  
 UNLESS OTHERWISE SPECIFIED

GASKET	EPDM RUBBER
BODY	HMWPE
STEEL COMPONENTS	316SS

CONFORMS TO:  
 BS 7775  
 DIN 19569-4

PART WEIGHT:  
 28.7 lbs.  
 REVISION:  
 A

AUTHOR:  
 TYLER KELLER  
 CHECKER:

DATE:  
 5/20/2026  
 UNITS:  
 INCHES

SCALE:  
 NOT TO SCALE  
 SHEET: 1 OF 1