

Coupling Sold Separately,
Contact Customer Service with Pipe OD

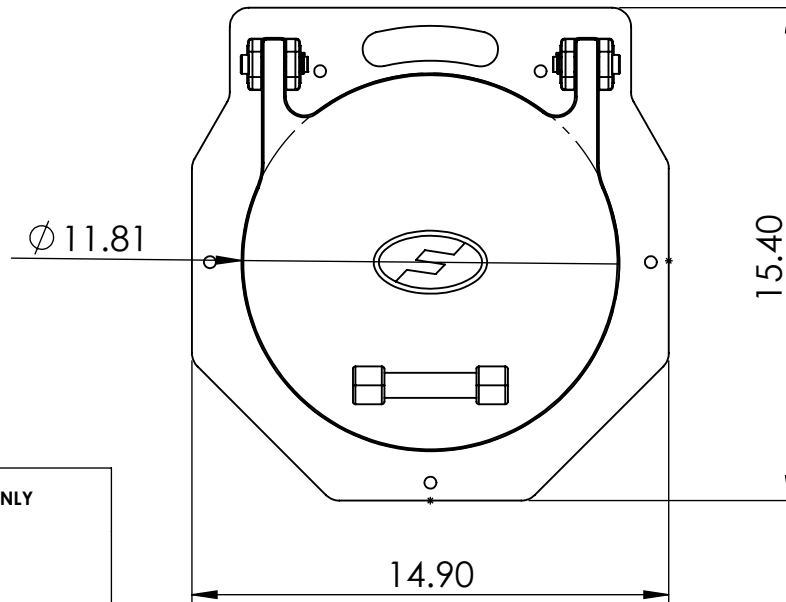

Enclosed 316 Steel
Counterweight System

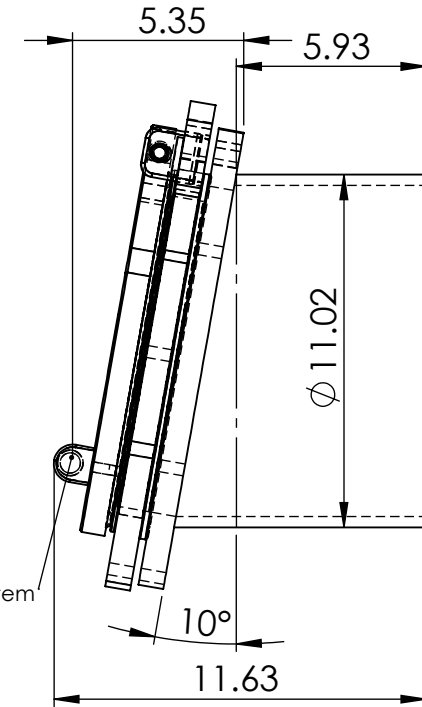

NOTE: FOR GRAVITY DRAINAGE APPLICATIONS ONLY

1. Working pressure of 10.75 PSI
2. Cracking head 0.4 PSI
3. Coupling Sold Separately
4. Exceeds the leakage rate and manufacturing requirements as per BS 7775 and DIN 19569-4 for a Class 5 valve.

PROPRIETARY AND CONFIDENTIAL
THE INFORMATION CONTAINED IN THIS
DRAWING IS THE SOLE PROPERTY OF
FERNCO, INC. ANY REPRODUCTION IN
PART OR AS A WHOLE WITHOUT THE
WRITTEN PERMISSION OF FERNCO, INC.
IS PROHIBITED.

TOLERANCES:
FRACTIONAL ± 1/4"
.XX = ± .06
ANG. = +3°
UNLESS OTHERWISE SPECIFIED

GASKET	EPDM RUBBER
BODY	HMPE
STEEL COMPONENTS	316SS

CONFORMS TO:
BS 7775
DIN 19569-4

PART WEIGHT:
19.5 LBS
REVISION:
A

AUTHOR:
TYLER KELLER
CHECKER:

DATE:
3/12/2026
UNITS:
INCHES

SCALE:
NOT TO SCALE
SHEET:
1 OF 1